

ANSER

3W GU10 LED Lamp

GLL47



An ideal lamp for both general and accent lighting. An even soft edge light from a 38° beam.
Good projection of light.

Cost of Light Comparison	
Greenled B	Conventional H

Guarantee: 2 Years

Non-Dimmable

CE	RoHS	90-240V AC	3W	25,000 hrs
----	------	---------------	----	---------------

Specifications	Specifications subject to change without notice		
Product Code	GLL47GU10C3W38	GLL47GU10N3W38	GLL47GU10W3W38
Colour	Cool White	Natural White	Warm White
Power Consumption	3W	3W	3W
Operational Voltage	90-240V AC	90-240V AC	90-240V AC
Colour Temperature	6,000 K	4,000 K	3,000 K
Intensity of Light Output	160 lm	135 lm	120 lm
Rendering Index	70 Ra	75 Ra	80 Ra
Lumens per Watt	54 lm/W	45 lm/W	40 lm/W
No. of LEDs	3	3	3
Expected Life	25,000 Hrs	25,000 Hrs	25,000 Hrs
Beam Angle	38°	38°	38°
Complexity of install	1	1	1
IES files available	Yes	Yes	Yes
Driver required	No	No	No

Dimensions

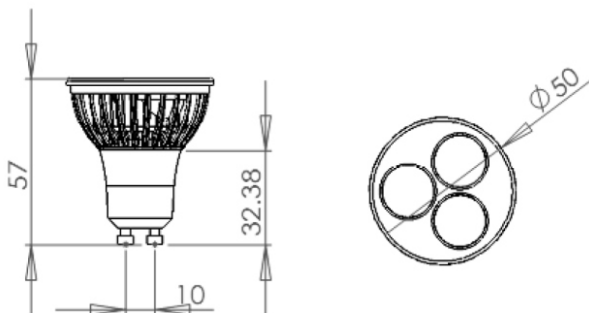

Cost of light is cost to buy, install, replace and run this light per year.
A: £1-10 B: £11-20 C: £21-30 and so on to Z: £250-260

Complexity of install: 1. User install - no Electrician req'd. 2. Some wiring - Electrician req'd. 3. Some wiring and installation work - Electrician req'd. 4. Additional wiring - Electrician req'd. 5 Fitting modification work - Electrician req'd.

Guarantee will ONLY apply where recommended drivers are used and fitting and installation is carried out by a properly qualified electrician.



Greenled is BS 8555 Certified

www.greenled.co.uk

Email: info@greenled.co.uk

Telephone: 01666 502 070